

**CARRIER, PERSONNEL, FULL TRACKED,
ARMORED FIRE SUPPORT,****M981 (NSN 2350-01-085-3792)**

References: TM 9-2350-266-10, TM 9-2350-266-20, TM 9-2350-261-20, TB 43-0210, and CL9100SL

Intervals (on-condition or hard time) and the related man-hour times are based on normal operation. The man-hour time specified is the time you need to do all the services prescribed for a particular interval. Hard time intervals will be indicated by one of the following symbols as appropriate: Daily (D), Weekly (W), Monthly (M), Semiannually (S), and Annually (A). On-Condition (OC) oil sample intervals shall be applied unless changed by the Army Oil Analysis Program (AOAP) laboratory. Change the hard time interval if your lubricants are contaminated or if you are operating the equipment under adverse operating conditions, including longer-than-usual operating hours. The hard time interval may be extended during periods of low activity. If extended, adequate preservation precautions must be taken. Hard time intervals will be applied in the event AOAP laboratory support is not available. Clean fittings before lubricating. Clean parts with dry cleaning solvent P-D-680. Dry before lubricating. Dotted arrow points indicate lubrication on both sides of the equipment.

LEVEL OF MAINTENANCE. The lowest level of maintenance authorized to lubricate a point is indicated by one of the following symbols as appropriate: Operator/Crew (C) and Unit Maintenance (O).

REPORTING ERRORS AND RECOMMENDING IMPROVEMENTS. You can help improve this manual. If you find any mistakes or if you know of a way to improve the procedures, please let us know. Mail your letter or DA Form 2028 (Recommended Changes to Publications and Blank forms) direct to: Commander, US Army Tank-Automotive Command, ATTN: AMSTA-MB, Warren, MI 48397-5000. A reply will be furnished to you.

WARNING

Dry cleaning solvent is toxic and flammable. Death or injury may result. To avoid death or injury, do the following:

Wear protective goggles and gloves and use only in well ventilated area. Avoid breathing vapors.

Avoid using near open flame or excessive heat (flash point is 100-138°F or 38-50°C).

If you become dizzy while using solvent, get fresh air immediately and get medical aid.

If contact with eyes is made, wash your eyes with water and get medical aid immediately.

NOTE

Park carrier on level ground to check oil levels. Check/lubricate all oil and grease fitting points after washing or fording.

ARMY OIL ANALYSIS PROGRAM (AOAP). AOAP is an effective maintenance diagnostic tool and not a maintenance substitute. TB 43-0210 must not be interpreted to mean AOAP minimizes, in any way, the need to employ good maintenance practices and strong maintenance disciplines.

Approved for public release; distribution is unlimited.

SAMPLING REQUIREMENTS. Samples may be taken without **WARMING** a component to operating temperature if the equipment has been operated within the last 30 days. If the equipment has not been operated within the last 30 days, the components must be brought to operating temperature. These requisites apply to both routine and special sampling. Oil samples must not be taken immediately after oil is added. When oil sampling valve is not available to take oil sample, use vampire pump to take samples.

SAMPLING PROCEDURES.

NOTE

DO NOT ADD OIL immediately prior to taking oil samples. When Daily operation checks and services indicate the need to replenish oil levels, **WAIT** until after taking samples. New oil added immediately prior to taking samples or before prolonged operation of components will adversely affect oil analysis results.

For location of nearest AOAP laboratory and complete information about AOAP, refer to TB 43-0210.

1. Perform Daily operation checks and services.
2. Obtain two sample bottles (NSN 8125-01-082-9697) and two DA Form 2026s from unit AOAP monitor.
3. Start the engine (TM 9-2350-266-10). If required (refer to Sampling Requirements), operate carrier to bring engine and transmission up to normal operating temperatures.
4. Stop carrier and set steering levers (TM 9-2350-266-10).

5. Place range selector in N position and keep engine running.

6. Remove driver's power plant access panel (TM 9-2350-266-10).

7. With engine running, remove dust caps from engine and transmission oil sampling valves.

8. Open sample valve on engine oil filter and drain small amount of oil into a suitable container to clear valve of grit and contamination. (Properly dispose of container and oil upon completion of sample taking.) Fill sampling bottle to neck shoulder and seal it. Attach DA Form 2026 to sample bottle.



9. Close oil sample valve and reinstall dust cap.

10. Take oil sample from transmission in same manner (steps 7 thru 9).

11. Shut off engine (TM 9-2350-266-10).

12. Install driver's compartment power plant access panel and secure carrier.

13. Deliver sample bottles to unit AOAP monitor.

LUBRICATION ORDER

19 March 1990

LO 9-2350-266-12

Supersedes LO 9-2350-266-12, dated 10 April 85.

**CARRIER, PERSONNEL, FULL TRACKED,
ARMORED FIRE SUPPORT,**

M981 (NSN 2350-01-085-3792)

References: TM 9-2350-266-10, TM 9-2350-266-20, TM 9-2350-261-20, TB 43-0210, and CL9100SL

LUBRICANT • INTERVAL

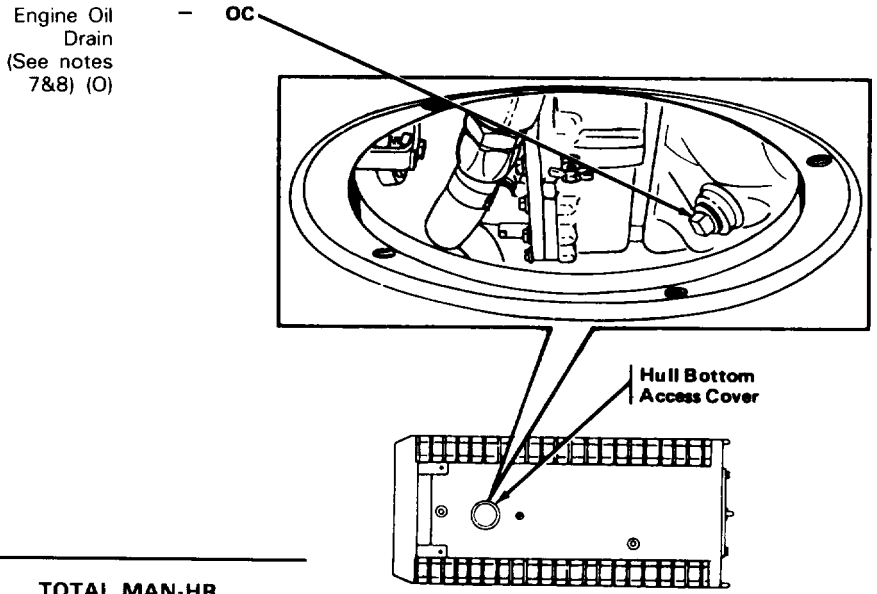
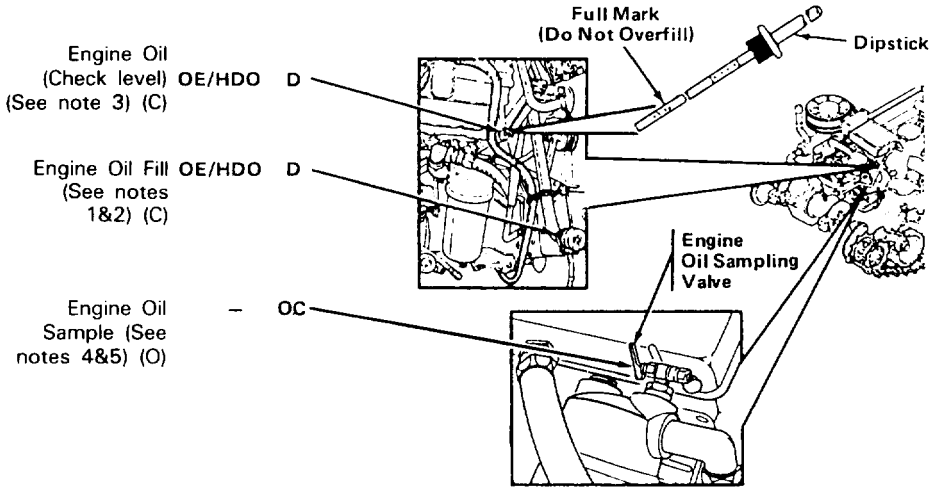

TOTAL MAN-HR

| INTERVAL | MAN-HR |
|----------|--------|
| D | 0.3 |
| OC | 0.5 |

LUBRICANT • INTERVAL

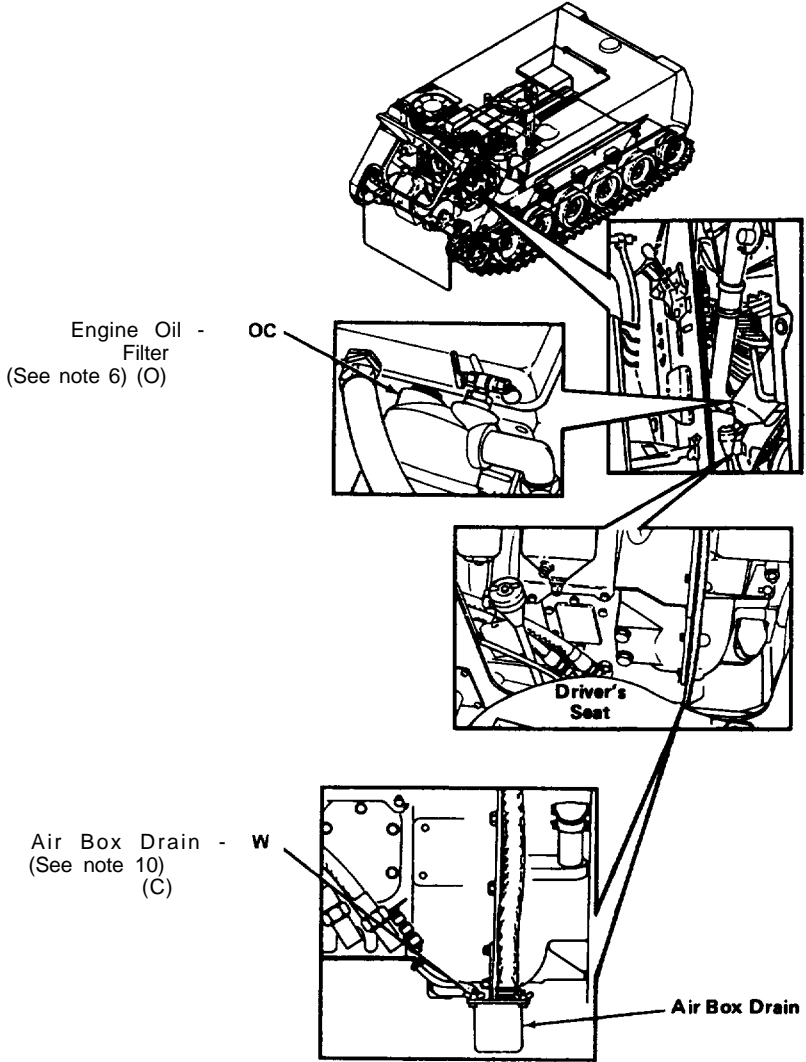

| TOTAL MAN-HR | |
|--------------|--------|
| INTERVAL | MAN-HR |
| W | 0.2 |
| OC | 0.3 |

LUBRICATION ORDER

LO 9-2350-266-12

19 March 1990

Supersedes LO 9-2350-266-12, dated 10 April 85.

**CARRIER, PERSONNEL, FULL TRACKED,
ARMORED FIRE SUPPORT,
M981 (NSN 2350-01-085-3792)**

References: TM 9-2350-266-10, TM 9-2350-266-20, TM 9-2350-261-20, TB 43-0210, and CL9100SL

KEY

| LUBRICANTS/ COMPONENTS | | CAPAC- ITIES (AP- PROX) | EXPECTED TEMPERATURE ¹ | | | INTERVALS |
|---|---|----------------------------------|--------------------------------------|---|---|---|
| | | | Above +32°F (Above 0°C) | +40°F to -10°F (+5°C to -23°C) | 0°F to -65°F (-18°C to -54°C) | |
| OE/HDO (MIL-L-2104D) OR OEA (MIL-L-46167) | LUBRICAT- ING OIL, INTERNAL COMBUSTION ENGINE Engine | 18 qts | OE/ HDO- 15/40 | OE/ HDO- 15/40 | OEA | D - Daily OC - On- Condi- tion |
| (MIL-L-21260) | PRESERVA- TION OIL | | PE- 30-1 | PE- 30-1 | | |

FOR ARCTIC OPERATION REFER TO FM 9-207

NOTES:

- When OE/HDO is used, this must NOT be mixed with single grade lubricants.
- Complete oil change with filters is required when converting from OE/HDO to OEA (PE-30-1 to OE/HDO or OEA; OEA to OE/HDO, etc.) in accordance with Key.

CAUTION

Engine can be damaged when engine is filled above F (full) mark.

NOTE

Park carrier on level ground to check oil levels. Check/lubricate all oil and grease fitting points after washing or fording.

- ENGINE OIL LEVEL. Before starting engine, check for oil level between F (full) and L (low) marks on gauge rod. Add oil as necessary. Oil level should not be above F mark.

4. FREQUENCY OF AOAP SAMPLE. Every 60 days, obtain sample of engine oil. Send this sample to nearest AOAP laboratory. For additional reference, see TB 43-0210. Routine samples are to be submitted at prescribed intervals. Samples should be taken as near prescribed interval as possible. If sampling at prescribed interval is not possible, a 10 percent variance before or after scheduled interval date or miles for sampling is permissible. The need for on-condition oil changes will be determined by AOAP laboratory.

5. HARD TIME INTERVAL. If AOAP laboratory support is not available, drain oil and change filter element/gasket every 1500 miles or annually. Hard time interval may be shortened if you are operating equipment under adverse conditions.

6. ENGINE OIL FILTER. Filter element will be replaced each time an engine oil change is required. (See TM 9-2350-261-20 for engine oil filter element removal/installation instructions.)

NOTE

Visual inspection of engine oil should not be justification to replace oil. Modern detergent engine oils, especially in diesel engines, may appear dark/black in color due to additives.

Drain oil only when hot (after engine operation). Allow oil to drain thoroughly.

7. ENGINE OIL DRAIN AND FILTER ELEMENT REPLACEMENT.

- a. Remove hull bottom access cover (TM 9-2350-261-20).
- b. Place suitable container of at least 5-gallon capacity under engine oil pan.
- c. Remove plug from engine oil pan and drain oil into container.
- d. Inspect plug and oil for metallic particles. If metal chips are found, notify direct support maintenance personnel.
- e. Clean and install drain plug in engine oil pan.
- f. Remove driver's access panel (TM 9-2350-266-10).
- g. Remove engine oil filter drain plug, filter cover, gasket, and filter element.

WARNING

Dry cleaning solvent burns easily, can cause skin rash, and can give off harmful vapors. To avoid injury, keep away from open fire and use in well-ventilated area. Wear protective clothing and rubber gloves.

- h. Clean inside of cover with dry cleaning solvent P-D-680.
- i. Install new filter element and gasket. Install filter cover. Make sure gasket is not crimped and forms a tight seal. Install drain plug.
- j. Fill engine with approximately 18 quarts of OE/HDO or OEA, as listed in Key, to bring level between F and L marks on gauge rod.

**CARRIER, PERSONNEL, FULL TRACKED,
ARMORED FIRE SUPPORT,
M981 (NSN 2350-01-085-3792)**

References: TM 9-2350-266-10, TM 9-2350-266-20, TM 9-2350-261-20, TB 43-0210, and CL9100SL

8. OPERATIONAL CHECK.

- a. Start engine and check for oil leaks at filter and drain plug with engine operating.
- b. Inspect hull bottom access cover for damage. Replace if damaged.
- c. Install hull bottom access cover (TM 9-2350-261-20).
- d. Install driver's access panel (TM 9-2350-266-10).

9. PRESERVATION OIL. If engine has been filled with preservation oil PE 30-1 by manufacturer or at time of overhaul, leave this oil in engine until first scheduled oil change. Maintain operating oil level by adding required quantity of applicable grade oil (OE/HDO or OEA). When first scheduled oil change is made, refill engine with applicable grade of oil (OE/HDO or OEA). (See notes 6&7 above.)

10. AIR BOX DRAIN AND AIR BOX RECEPTACLE. Weekly, remove engine access cover and empty receptacle. To remove receptacle, remove two thumbscrews and slowly lower receptacle. Empty receptacle and remove element. Clean element and inside of receptacle with dry cleaning solvent P-D-680 and reinstall (TM 9-2350-261-20).

**CARRIER, PERSONNEL, FULL TRACKED,
ARMORED FIRE SUPPORT,
M981 (NSN 2350-01-085-3792)**

References TM 9-2350-266-10, TM 9-2350-266-20, TM 9-2350-261-20, TB 43-0210, and CL9100SL

WARNING

Fuel is flammable. Always use in area with good air flow, away from heat or flames. DO NOT breathe fumes. If fuel gets on hands, wash them. If fuel gets in eyes, flush with water and get medical help. Keep fire extinguisher nearby.

LUBRICANT • INTERVAL

Fuel Filter - **A**
Change
(2 places)
(See note 2) (O)

Fuel Filter - **D**
Drain
(2 places)
(See note 1) (C)

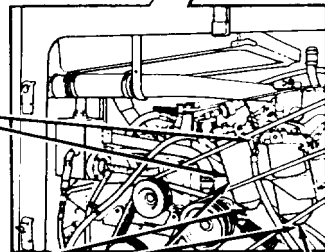
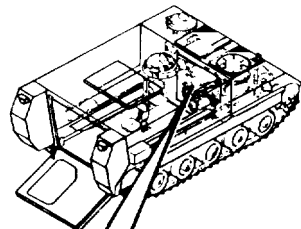

Secondary Fuel filter

Primary Fuel Filter

TOTAL MAN-HR

| INTERVAL | MAN-HR |
|----------|--------|
| D | 0.3 |
| A | 0.3 |

KEY

| LUBRICANTS/ COMPONENTS | | CAPAC- ITIES (AP- PROX) | EXPECTED TEMPERATURE | | | INTERVALS |
|---------------------------|----------------|----------------------------------|-------------------------------------|--|---|---|
| | | | Above + 32 ° F (Above 0°C) | + 40 ° F - 10 ° F (+ 5°C - 23 ° C) | 0°F to - 65 ° F (- 18 ° C - 54 ° C) | |
| W - F - 800 | DIESEL FUEL | 95 gal | DF-2 | DF-1 | DF-A | A - Annu - ally or Every 1500 Miles |

FOR ARCTIC OPERATION REFER TO FM 9-207

NOTES:

1. FUEL FILTER DRAIN. Before operation, drain water and sediment from primary and secondary fuel filters as follows:

- a. Remove rear power plant access panels (TM 9-2350-266-10).
- b. Place suitable container under primary fuel filter. Open drain cock and drain water and sediment from primary fuel filter. When clean fuel starts to drain out, close drain cock.
- c. Repeat step b above for secondary fuel filter.
- d. Check for fuel leaks at primary and secondary fuel filters while engine is running. If leak is found, shut down engine immediately and notify unit maintenance.

2. FUEL FILTER CHANGE. Every 1500 miles or annually, replace fuel filter elements. With engine stopped and master switch OFF, place suitable container under fuel filters. Drain both filters. Remove primary filter shell first and then secondary fuel filter. Clean inside of shells. Install new elements into shells. Prefill primary and secondary shells with fuel. Install shells. Install rear power plant access panels (TM 9-2350-266-10). If engine will not start or hesitates, problem may be trapped air; drain fuel filter per note 1 above.

**CARRIER, PERSONNEL, FULL TRACKED,
ARMORED FIRE SUPPORT,
M981 (NSN 2350-01-085-3792)**

References: TM 9-2350-266-10, TM 9-2350-266-20, TM 9-2350-261-20, TB 43-0210, and CL9100SL

LUBRICANT • INTERVAL

Transfer Gearcase (Check level) (See note) (C)

OE/HDO or OEA D

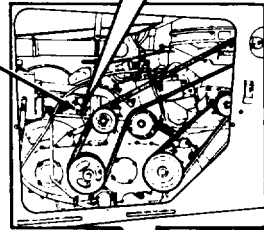
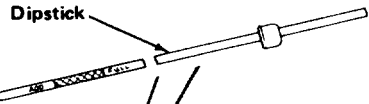

Transfer Gearcase Drain (See note) (O)

S

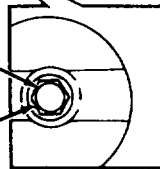
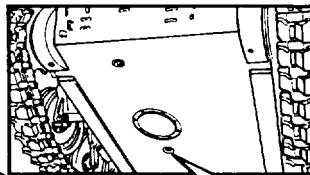

Drain Plug

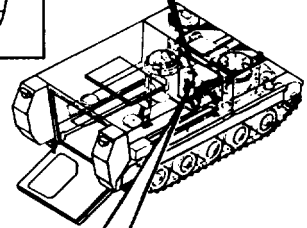

Transfer Gearcase Fill (See note) (C)

OE/HDO D

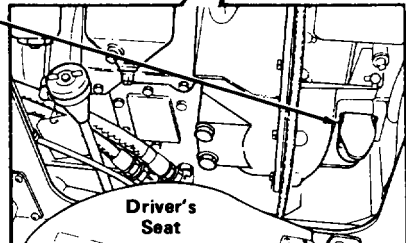

Driver's Seat

TOTAL MAN-HR

| INTERVAL | MAN-HR |
|----------|--------|
| D | 0.2 |
| S | 0.5 |

KEY

| LUBRICANTS/ | | CAPACITIES (APPROX) | EXPECTED TEMPERATURE | | | |
|---|---|---------------------|-------------------------|----------------------------------|-------------------------------------|--|
| | | | + 32 ° F (Above 0°C) | - 10 ° F (+ 5°C - 23 ° C) | - 65 ° F (- 18 ° C - 54 ° C) | |
| OE/HDO MIL-L-2104D) OR OEA MIL-L-46167) | LUBRICATING OIL, INTERNAL COMBUSTION ENGINE Transfer Gearcase | 2-1/2 qts | OE/HDO-15/40 | OE/HDO-10 | OEA | D - Daily S - Semi-annually or Every 1500 Miles |

FOR ARCTIC OPERATION REFER TO FM 9-207

NOTE:

TRANSFER GEARCASE. Daily, check level of oil in transfer gearcase. Add oil (OE/HDO or OEA), as needed, to bring oil level between ADD and FULL marks on gauge rod. Every 150 hours, 1500 miles, or semiannually, drain gearcase oil. Drain only when hot(after operation). To drain, remove hull drain plug (TM 9-2350-261-20) and gearcase drain plug. Check oil being drained for metallic particles. If metal chips are found in oil, notify direct support maintenance. Drain at least 15 minutes. Clean and install gearcase drain plug. Fill transfer gearcase with approximately 2-1/2 quarts of oil (OE/HDO or OEA). Make sure gearcase filler cap is closed. Start engine and operate for 1 minute. Stop engine and check oil level. Level should be between FULL and ADD marks on gauge rod. Install hull drain plug securely.

LUBRICATION ORDER

19 March 1990

LO 9-2350-266-12

Supersedes LO 9-2350-266-12, dated 10 April 85.

CARRIER, PERSONNEL, FULL TRACKED, ARMORED FIRE SUPPORT, M981 (NSN 2350-01-085-3792)

References: TM 9-2350-266-10, TM 9-2350-266-20, TM 9-2350-261-20, TB 43-0210, and CL9100SL

LUBRICANT • INTERVAL

Differential Breather
Remove, Clean,
Dry and Install
(See note 1) (O)

Differential Fill and Level
(Check level)
(See note 2) (C)
OE/HDO
OEA

Differential Oil Filter
(See note 4) (O)

Differential Drain
(See note 3) (O)

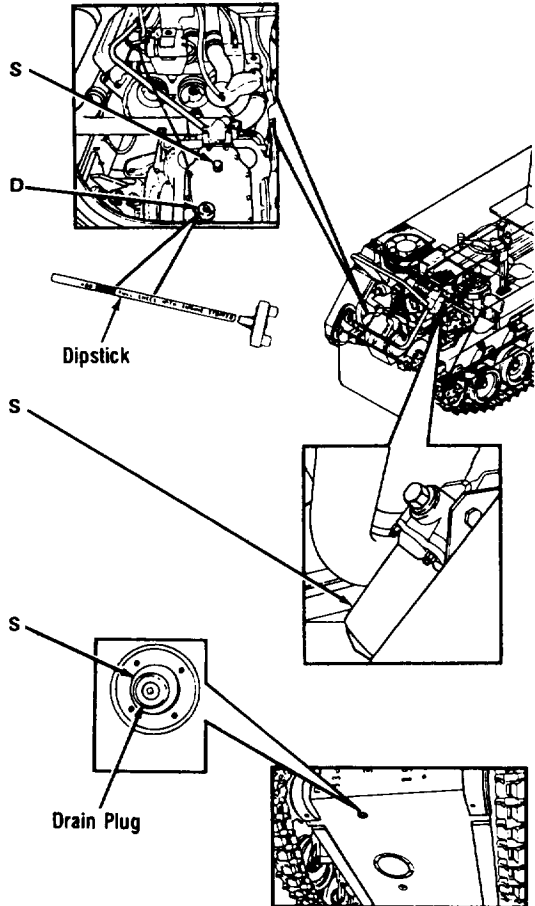

TOTAL MAN-HR

| INTERVAL | MAN-HR |
|----------|--------|
| D | 0.2 |
| S | 0.2 |

KEY

| LUBRICANTS/ COMPONENTS | | CAPAC- ITIES (AP- PROX) | EXPECTED TEMPERATURE | | | INTERVALS |
|---|---|----------------------------------|-----------------------------------|---------------------------------------|--|---|
| | | | Above +32 °F (Above 0°C) | +40 °F -10 °F (+ 5°C -23 °C) | 0°F to -65 °F (-18 °C -54 °C) | |
| OE/HDO MIL-L-2104D) OEA MIL-L-46167) | LUBRICAT- ING OIL, INTERNAL COMBUSTION ENGINE Differential | 20 qts | OE/ HDO 15/4(| OE/ HDO- 10 | OEA | D - Daily S - Semi- annu- ally, or Every 150 Hours or 1500 Miles |

FOR ARCTIC OPERATION REFER TO FM 9-207

NOTES:

WARNING

Dry cleaning solvent burns easily, can cause skin rash, and can give off harmful vapors. To avoid injury, keep away from open fire and use in well-ventilated area. Wear protective clothing and rubber gloves.

DIFFERENTIAL BREATHER. Every 150 hours, 1500 miles, or semiannually, remove and clean beather with dry cleaning solvent P-D-680. Then dry and install breather (TM 9-2350-261-20).

NOTE

Do not use AOAP on differential. There are metal particles in brake shoes material that can give a false reading.

DIFFERENTIAL LEVEL. Before operation, check differential oil level to be sure there is enough oil for warmup operation. Add oil (OE/HDO or OEA) only if level is below safe range.

DIFFERENTIAL DRAIN. Every 100 hours, 1500 miles, or semiannually, drain differential. rain only when hot (after operation). To drain, remove front hull drain plug (TM 9-2350-261-20) and differential drain plug. Check differential drain plug for metallic particles. If metal chips are found, notify direct support maintenance.

DIFFERENTIAL OIL FILTER. Filter is to be cleaned each time a differential oil change is required. Every 150 hours, 1500 miles, or semiannually, clean differential oil filter. Remove four nuts, flat washers, and screws securing filter body on head, and remove body (TM 9-2350-261-20). Remove element, clean housing and element with dry cleaning solvent P-D-680, and install element and housing. If element or preformed packings are unserviceable, stall new packings and element using differential oil filter kit. Install element using differential oil ter kit. Install element and body on head, and secure with four screws, flat washers, and nuts. Tighten nuts to 4 to 6 pound-feet torque. After filling differential, check for oil leaks at filter with engine running.

LUBRICATION ORDER

19 March 1990

LO 9-2350-266-12

Supersedes LO 9-2350-266-12, dated 10 April 85.

CARRIER, PERSONNEL, FULL TRACKED, ARMORED FIRE SUPPORT, M981 (NSN 2350-01-085-3792)

References: TM 9-2350-266-10, TM 9-2350-266-20, TM 9-2350-261-20, TB 43-0210, and CL9100SL

LUBRICANT • INTERVAL

Transmission
Drain (See
notes 7, 8 & 9) - OC
(O)

Transmission - OC
Oil Filter (See
notes 2&6)
(O)

Transmission OE/HDO
Fill and Level or
(Check level) OEA
(See notes
1&3) (C)

Transmission
Oil Sample
(See notes
4&5)

Final Drive
Fill and Level (Check
level) (See
note 10) (C)

Final Drive
Drain (See
note 11) (O)

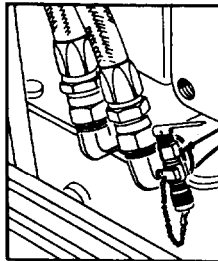
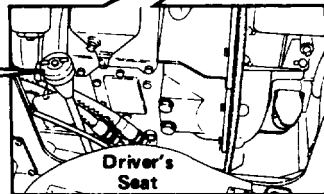
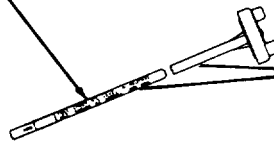
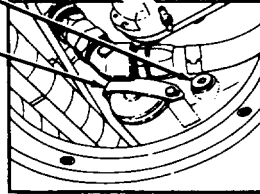
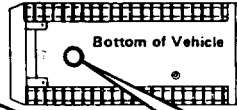

Final Drive Dipstick

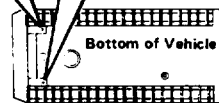
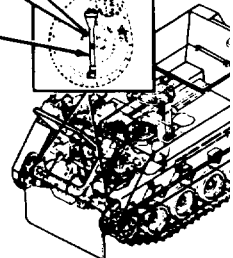
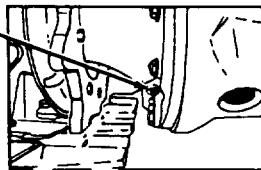

TOTAL MAN-HR

| INTERVAL | MAN-HR |
|----------|--------|
| D | 0.2 |
| S | 0.5 |
| OC | 0.5 |

KEY

| LUBRICANTS/ COMPONENTS | | CAPAC- ITIES (AP- PROX) | EXPECTED TEMPERATURE | | | INTERVALS |
|---|---|----------------------------------|-------------------------------------|--|--|--|
| | | | Above + 32 ° F (Above 0°C) | + 40 ° F - 10 ° F (+ 5°C - 23 ° C) | 0° F to - 65 ° F - 18 ° C - 54 ° C) | |
| OE/HDO MIL-L-2104D) OR OEA MIL-L-46167) | LUBRICAT- ING OIL, INTERNAL COMBUSTION ENGINE | | OE/ HDO- 15/40 | OE/ HDO- 15/40 | OEA | D – Daily S – Semi- annu- ally or Every 1500 Miles OC – On- Condi- tion |
| | Transmission | 16 qts | | | | |
| | Final Drives | 3-1/2 qts | | | | |
| (MIL-L-21260) | PRESERVA- TION OIL | | PE- 10-1 | PE- 10-1 | | |

FOR ARCTIC OPERATION REFER TO FM 9-207

NOTES:

- When OE/HDO is used, this must not be mixed with single grade lubricants.
- Complete oil change with filters is required when converting from OE/HDO to OEA (OEA to OE/HDO) in accordance with Key.

CAUTION

Transmission can be damaged when filled above FULL mark. Check transmission oil level before operation. Transmission oil level should be between ADD and FULL marks on gauge rod.

NOTE

Park carrier on level ground to check oil levels. Check/lubricate all oil and grease fitting point after washing or fording.

- TRANSMISSION OIL LEVEL.** Before operation, check transmission oil level. Remove driver's access panel (TM 9-2350-266-10). Add oil (OE/HDO or OEA), as needed, to bring oil level between ADD and FULL marks on gauge rod. With engine disconnect engaged, start and run engine at 800 rpm for 3 to 5 minutes with range lever in 2-3 and brakes locked to allow transmission oil to reach normal operating temperature. With engine idling, move range lever through all ranges to assure complete oil circulation. Return range lever to N, and check transmission oil level with engine operating at 1500 rpm.

LUBRICATION ORDER

LO 9-2350-266-12

19 March 1990

Supersedes LO 9-2350-266-12, dated 10 April 85.

CARRIER, PERSONNEL, FULL TRACKED, ARMORED FIRE SUPPORT, M981 (NSN 2350-01-085-3792)

References: TM 9-2350-266-10, TM 9-2350-266-20, TM 9-2350-261-20, TB 43-0210, and CL9100SL

4. FREQUENCY OF AOAP SAMPLE. Every 60 days, obtain sample of transmission oil. Send this sample to nearest AOAP laboratory. For additional reference, see TB 43-0210. Routine samples are to be submitted at prescribed intervals. Samples should be taken as near prescribed interval as possible. If sampling at prescribed interval is not always possible, a 10 percent variance before or after scheduled interval date or miles for sampling is permissible. The need for on-condition oil changes will be determined by AOAP laboratory.

5. HARD TIME INTERVAL. If AOAP laboratory support is not available, drain transmission every 150 hours, 1500 miles, or semiannually. Drain only when hot (after operation).

6. TRANSMISSION OIL FILTER. Filter element will be replaced each time a transmission oil change is required. (See TM 9-2350-261-20 for transmission oil filter element removal/installation instructions.)

NOTE

Visual inspection of transmission oil should not be justification to replace oil. Modern detergent transmission oils may appear dark in color due to the additives.

Drain oil only when hot (after operation). Allow oil to drain thoroughly for 1 hour if time permits.

7. TRANSMISSION OIL DRAIN AND FILTER ELEMENT REPLACEMENT.

- a. Remove hull bottom access cover (TM 9-2350-261-20).
- b. Place a suitable container under transmission drain plug.
- c. Remove plug from transmission and drain oil into container. Allow oil to drain thoroughly - 1 hour if time permits.
- d. Inspect plug and oil for metallic particles. If metal chips are found, notify direct support maintenance personnel.
- e. Clean and install drain plug to transmission.

WARNING

Dry cleaning solvent burns easily, can cause skin rash, and can give off harmful vapors. To avoid injury, keep away from open fire and use in well-ventilated area. Wear protective clothing and rubber gloves.

- f. Remove element, clean cavity with dry cleaning solvent P-D-680, and install new element.
- g. Fill transmission with approximately 16 quarts (refill capacity) of OE/HDO or OEA, as listed in Key, to bring level between FULL and ADD marks on gauge rod.
- h. After filling transmission, check for oil leaks at filter with engine running.

8. OPERATIONAL CHECK.

- a. Start engine and check for oil leaks at transmission filter cover and drain plug. Recheck oil level.
- b. Inspect hull bottom access cover for damage (TM 9-2350-261-20).
- c. Install hull bottom access cover (TM 9-2350-261-20).
- d. Install driver's access panel (TM 9-2350-266-10).

NOTE

Transmission oil must be flushed when changing oil grades.

Do not change transmission oil filter at this time.

9. TRANSMISSION OIL FLUSH PROCEDURE. Use the following procedure when changing oil grade or when oil is contaminated:

- a. Operate carrier until coolant reaches normal operation temperature.
- b. Drain transmission oil.
- c. Fill transmission with new grade oil.
- d. Position range selector in 1-3 with engine idling for 5 to 6 minutes.
- e. Drain oil and change transmission oil filter.
- f. Fill transmission with new grade oil.
- g. Check oil level.

10. FINAL DRIVES. Weekly, check oil in both final drives for level between ADD and FULL marks on gauge rod. Add applicable OE/HDO or OEA, in accordance with Key, as required.

LUBRICATION ORDER**LO 9-2350-266-12**

19 March 1990

Supersedes LO 9-2350-266-12, dated 10 April 85.

**CARRIER, PERSONNEL, FULL TRACKED,
ARMORED FIRE SUPPORT,
M981 (NSN 2350-01-085-3792)**

References: TM 9-2350-266-10, TM 9-2350-266-20, TM 9-2350-261-20, TB 43-0210, and CL9100SL

NOTE

Drain only when hot (after operation).

Do not substitute hydraulic fluid for OE/HDO or OEA. Red dye has been added to some final drives to aid in detection of leaks.

11. FINAL DRIVE OIL DRAIN. Every 1500 miles or semiannually, drain final drives:
 - a. Place a suitable container under final drive housing.
 - b. Remove drain plugs from final drive housing and drain oil into container (TM 9-2350-261-20).
 - c. Inspect drain plugs and oil for metallic particles. If metal chips are found, notify direct support maintenance.
 - d. Clean and install drain plug (TM 2350-261-20).
 - e. Fill each final drive with OE/HDO or OEA in accordance with Key, adding the proper amount to bring level to a point between the FULL and ADD marks on gauge rod. Each final drive takes approximately 3-1/2 quarts.

LUBRICATION ORDER

LO 9-2350-266-12

19 March 1990

Supersedes LO 9-2350-266-12, dated 10 April 85.

CARRIER, PERSONNEL, FULL TRACKED, ARMORED FIRE SUPPORT, M981 (NSN 2350-01-085-3792)

References: TM 9-2350-266-10, TM 9-2350-266-20, TM 9-2350-261-20, TB 43-0210, and CL9100SL

LUBRICANT • INTERVAL

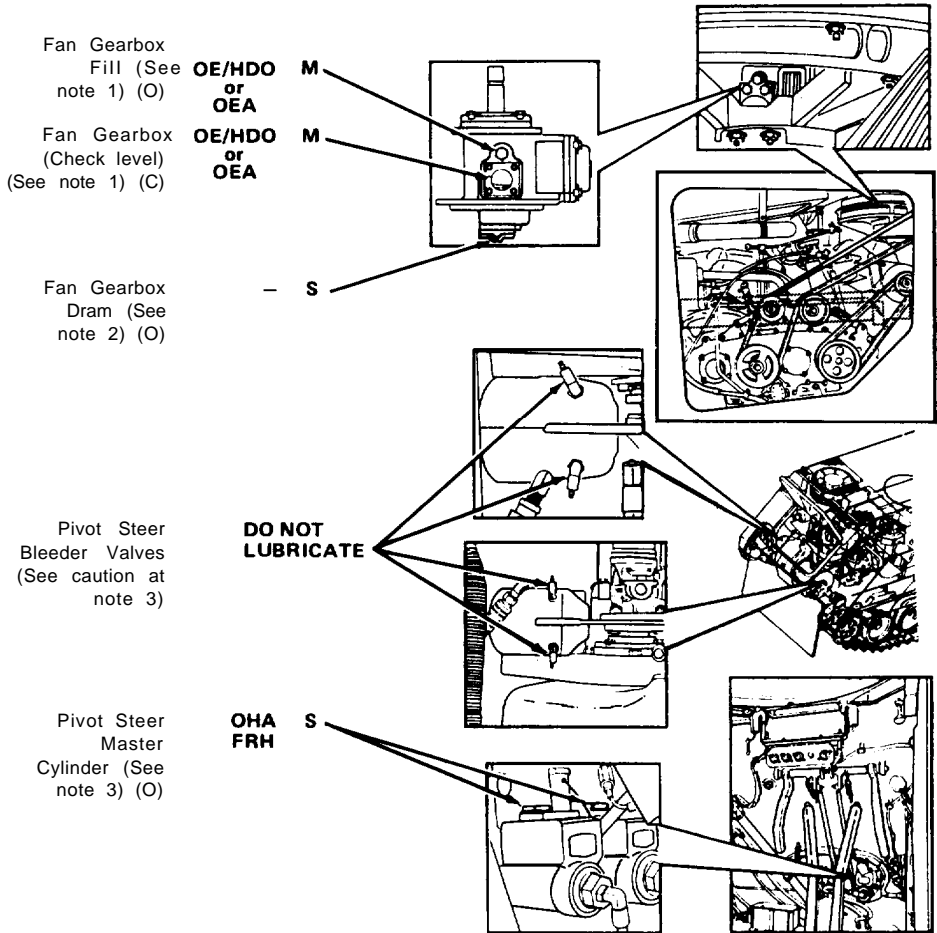

TOTAL MAN-HR

| INTERVAL | MAN-HR |
|----------|--------|
| M | 0.2 |
| S | 0.3 |

KEY

| LUBRICANTS/ COMPONENTS | | CAPAC- ITIES (AP- PROX) | EXPECTED TEMPERATURE | | | INTERVALS |
|---|--|----------------------------------|-------------------------------------|--|---|---|
| | | | Above + 32 ° F (Above 0°C) | + 40 ° F to - 10 ° F (+ 5°C - 23 ° C) | 0°F to - 65 ° F (- 18 ° C - 54 ° C) | |
| OE/HDO (MIL-L-2104D) OR OEA (MIL-L-46167) | LUBRICAT- ING OIL, INTERNAL COMBUSTION ENGINE Fan Gearbox | 10 oz | OE/ HDO- 15/40 | OE/ HDO- 15/40 | OEA | M - Month- ly S - Semi- annu- ally or Every 1500 Miles |
| OHA (MIL-H-5606) | HYDRAULIC FLUID, PETROLEUM BASE | 1 pt | ALL TEMPERATURES | | | |
| FRH (MIL-H-46170) | HYDRAULIC FLUID, RUST INHIBITED, FIRE RESISTANT, SYNTHETIC HYDRO- CARBON BASE Pivot Steer System | | | | | |

FOR ARCTIC OPERATION REFER TO FM 9-207

NOTES:

FAN GEARBOX. Monthly, check fan gearbox oil level. Oil level should be to center of sight glass. Add OE/HDO or OEA, as needed, to bring up to level.

NOTE

Drain only when hot (after operation).

FAN GEARBOX OIL DRAIN. Every 1500 miles or semiannually, drain fan gearbox. To drain and refill gearbox, see steps a thru g below:

- a. Place suitable container under fan gearbox drain.
- b. Remove drain plug and preformed packing from gearbox housing and drain oil into container. Discard packing.

**CARRIER, PERSONNEL, FULL TRACKED,
ARMORED FIRE SUPPORT,
M981 (NSN 2350-01-085-3792)**

References TM 9-2350-266-10, TM 9-2350-266-20, TM 9-2350-261-20, TB 43-0210, and CL9100SL

- c. Check drain plug and oil for metallic particles and foreign matter.
- d. Clean drain plug and apply antiseize compound (TM 9-2350-261-20).
- e. Lubricate new preformed packing with oil prior to installing.
- f. Install drain plug with new preformed packing in gearbox housing.
- g. Fill gearbox with approximately 10 ounces of oil (OE/HDO or OEA) to bring level to center of sight glass.

WARNING

Hydraulic fluid is toxic to skin, eyes, and respiratory system. Wear skin, eye, and respiratory protection while doing this procedure.

CAUTION

Use only hydraulic fluid indicated. DO NOT use brake fluid DO NOT overfill.

DO NOT mix hydraulic fluid types. Damage to the hydraulic system may result.

DO NOT grease pivot steer bleeder valves.

3. PIVOT STEER SYSTEM. Every 150 hours, 1500 miles, or semiannually, remove plugs and check fluid level in both master cylinders (TM 9-2350-261-20). Add fluid, as required, to bring fluid within 1/2 to 3/4 inch from top of cylinder.

**CARRIER, PERSONNEL, FULL TRACKED,
ARMORED FIRE SUPPORT,
M981 (NSN 2350-01-085-3792)**

References: TM 9-2350-266-10, TM 9-2350-266-20, TM 9-2350-261-20, TB 43-0210, and CL9100SL

LUBRICANT • INTERVAL

- Hydraulic Tank Fill (See note 1) (C) OHA
FRH
OHT D
- Hydraulic Tank Level (See note 1) (C) OHA
FRH
OHT D
- Hydraulic Tank Filter (See note 2) (O) OHA
FRH
OHT S
- Hydraulic Tank Drain and Breather (See note 2) (O) OHA
FRH
OHT S

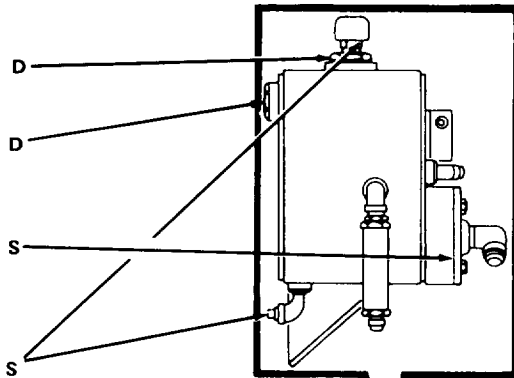

| | |
|--------------|--------|
| TOTAL MAN-HR | |
| INTERVAL | MAN-HR |
| D | 0.2 |
| S | 1.0 |

KEY

| LUBRICANTS/ COMPONENTS | | CAPAC- ITIES (AP- PROX) | EXPECTED TEMPERATURE | | | INTERVALS |
|-----------------------------|--|----------------------------------|-------------------------------------|--|--|---|
| | | | Above + 32 ° F (Above 0°C) | + 40 ° F - 10 ° F (+ 5°C - 23 ° C) | 0°F to - 65 ° F (- 18 ° C - 54 ° C) | |
| OHA (MIL-H-5606) | HYDRAULIC FLUID, PETROLEUM BASE | 2 qts | ALL TEMPERATURES | | | D - Daily S - Semi- annu- ally or Every 1500 Miles |
| FRH MIL-H-46170) | HYDRAULIC FLUID, RUST INHIBITED, FIRE RESISTANT, SYNTHETIC HYDRO- CARBON BASE | | | | | |
| OHT (MIL-H-6083) | HYDRAULIC FLUID, PETROLEUM BASE, FOR PRESERVA- TION AND OPERATION Ramp System | | | | | |

FOR ARCTIC OPERATION REFER TO FM 9-207

NOTES:

HYDRAULIC SYSTEM TANK. With ramp down and carrier on level ground, check hydraulic fluid level. Fluid level should be halfway in sight glass. To add OHA, FRH, or OHT, remove fill plug and preformed packing from top of tank. Add OHA, FRH, or OHT as needed. Install fill plug and new preformed packing.

Every 1500 miles or semiannually, drain hydraulic system tank and service strainer. Drain hydraulic system tank as follows:

- a. Lower ramp (TM 9-2350-266-10)
- b. Place a suitable container of at least 2-gallon capacity under drain elbow in bottom of tank and remove plug.

LUBRICATION ORDER**LO 9-2350-266-12**

19 March 1990

Supersedes LO 9-2350-266-12, dated 10 April 85.

**CARRIER, PERSONNEL, FULL TRACKED,
ARMOREO FIRE SUPPORT,
M981 (NSN 2350-01-085-3792)**

References: TM 9-2350-266-10, TM 9-2350-266-20, TM 9-2350-261-20, TB 43-0210, and CL9100SL

WARNING

Dry cleaning solvent burns easily, can cause skin rash, and can give off harmful vapors. To avoid injury, keep away from open fire and use in well-ventilated area. Wear protective clothing and rubber gloves.

CAUTION

DO NOT use compressed air to dry filter. Damage will result.

DO NOT mix hydraulic fluid types. Damage to the hydraulic system may result.

- c. Disconnect hose at filter adapter elbow. Remove four machine bolts and key washers that secure filter to tank. Discard key washers. Remove filter from adapter and wash thoroughly in dry cleaning solvent P-D-680.
- d. Remove breather and wash thoroughly in dry cleaning solvent P-D-680 (TM 9-2350-261-20-2).
- e. Clean interior of tank through filter opening using dry cleaning solvent P-D-680 and clean cloth. Discard packing.
- f. Install new packing and filter on adapter. Secure adapter to tank with four new key washers and four machine bolts. Connect hose to adapter elbow.
- g. Fill tank with fluid (OHA, FRH, or OHT) (2 quarts) to bring level between MAX and MIN marks.
- h. Install breather into fill plug. Install fill plug and new packing into tank (TM 9-2350-261-20-2).
- i. Operate ramp and check for leaks.

LUBRICATION ORDER

LO 9-2350-266-12

19 March 1990

Supersedes LO 9-2350-266-12, dated 10 April 85.

**CARRIER, PERSONNEL, FULL TRACKED,
ARMORED FIRE SUPPORT,
M981 (NSN 2350-01-085-3792)**

References: TM 9-2350-266-10, TM 9-2350-266-20, TM 9-2350-261-20, TB 43-0210, and CL9100SL

LUBRICANT • INTERVAL

Steering Control Lever **G A A S**
(Every 150 hours, 1500 miles, or semi-annually lubricate steering control lever shaft bearing.) (O)

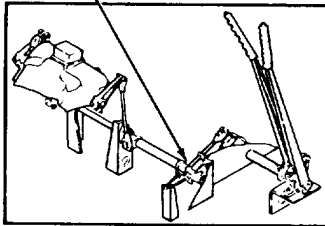
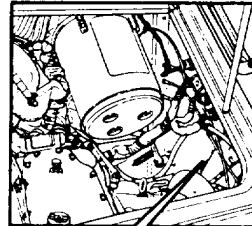

Towing Pintle **G A A S**
(If two fittings are installed, lubricate every 150 hours, 1500 miles, or semi-annually.) (See note) (O)

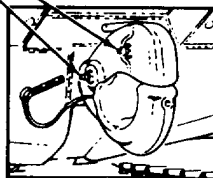
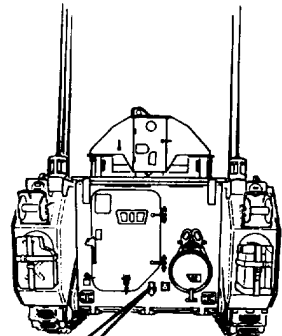

TOTAL MAN-HR

| INTERVAL | MAN-HR |
|----------|--------|
| S | 0.2 |

KEY

| LUBRICANTS/ COMPONENTS | | CAPAC- ITIES (AP- PROX) | EXPECTED TEMPERATURE | | | INTERVALS |
|-----------------------------|---|----------------------------------|----------------------------------|-----------------|-------------------------------------|--|
| | | | Above +32°F (Above 0°C) | +40°F (+5°C) | 0°F to -65°F (-18°C -54°C) | |
| GAA MIL-G-10924) | GREASE, AUTOMOTIVE AND ARTILLERY Towing Pintle and Steering Control Lever | As req | ALL TEMPERATURES | | | S - Semi- annu- ally or Every 1500 Miles or 150 Hours |

FOR ARCTIC OPERATION REFER TO FM 9-207

NOTE:

NOTE

Late model towing pintles do not have grease fittings and do not require lubrication.

TOWING PINTLE. Every 150 hours, 1500 miles, or semiannually, lubricate pintle through two fittings with GAA.

LUBRICATION ORDER

19 March 1990

LO 9-2350-266-12

Supersedes LO 9-2350-266-12, dated 10 April 85.

**CARRIER, PERSONNEL, FULL TRACKED,
ARMORED FIRE SUPPORT,
M981 (NSN 2350-01-085-3792)**

References: TM 9-2350-266-10, TM 9-2350-266-20, TM 9-2350-261-20, TB 43-0210, and CL9100SL

LUBRICANT • INTERVAL

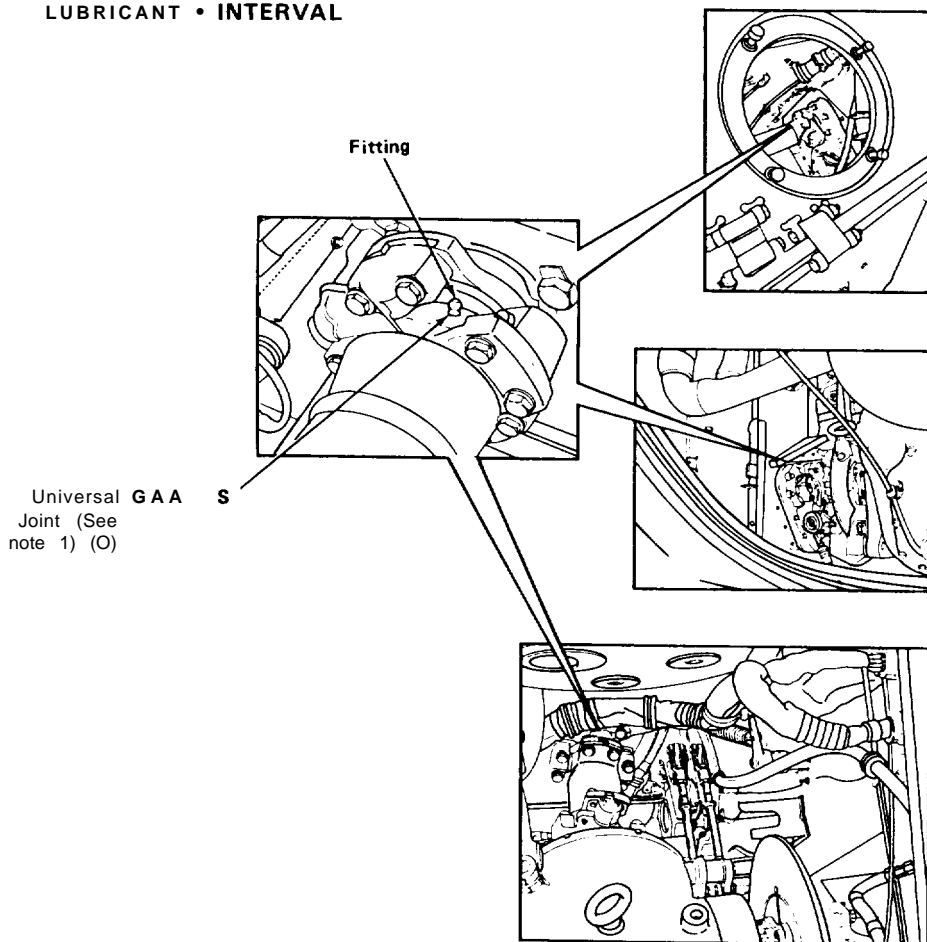

| TOTAL MAN-HR | |
|--------------|--------|
| INTERVAL | MAN-HR |
| S | 0.3 |

KEY

| LUBRICANTS/ COMPONENTS | | CAPAC- ITIES (AP- PROX) | EXPECTED TEMPERATURE | | | INTERVALS |
|------------------------------|--|----------------------------------|---------------------------------------|--|---|--|
| | | | Above + 32 ° F (Above 0 ° C) | + 40 ° F to - 10 ° F (+ 5 ° C - 23 ° C) | 0 ° F to - 65 ° F (- 18 ° C - 54 ° C) | |
| GAA (MIL-G-10924) | GREASE, AUTOMOTIVE AND ARTILLERY Universal Joint | As req | ALL TEMPERATURES | | | S - Semi- annu- ally or Every 1500 Miles or 150 Hours |

FOR ARCTIC OPERATION REFER TO FM 9-207

NOTES:

1. UNIVERSAL JOINTS. Every 150 hours, 1500 miles, or semiannually, lubricate all universal joints and propeller shaft bearings with grease (GAA) (6 places). Each universal joint spider has two fittings, but only one of each pair of fittings requires lubrication.

WARNING

Dry cleaning solvent burns easily, can cause skin rash, and can give off harmful vapors. To avoid injury, keep away from open fire and use in well-ventilated area. Wear protective clothing and rubber gloves.

NOTE

When grease fitting will not accept GAA, notify unit maintenance.

2. Clean fittings with dry cleaning solvent P-D-680 prior to lubrication. Check/lubricate grease fitting points after washing or fording.

LUBRICATION ORDER

LO 9-2350-266-12

19 March 1990

Supersedes LO 9-2350-266-12, dated 10 April 85.

**CARRIER, PERSONNEL, FULL TRACKED,
ARMORED FIRE SUPPORT,
M981 (NSN 2350-01-085-3792)**

References: TM 9-2350-266-10, TM 9-2350-266-20, TM 9-2350-261-20, TB 43-0210, and CL9100SL

LUBRICANT • INTERVAL

Idler Wheel
Support Arm
Bearings
(2 places) (See
notes 1&4) (C)

GAA S

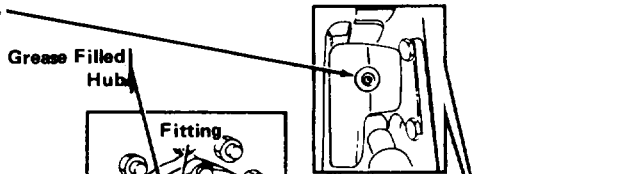

Road Wheel
and Idler
Wheel Hub
Bearings (12
places) (See
notes 2&4) (C)

GAA S

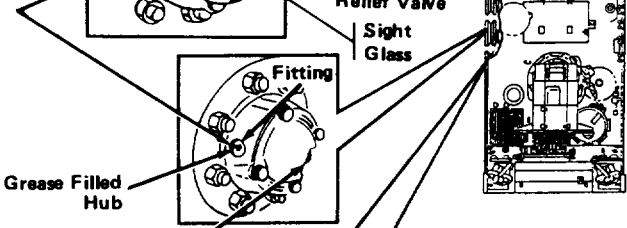

Road Wheel
Support Arm
Bearings (10
places) (See
notes 3&4) (C)

GAA S

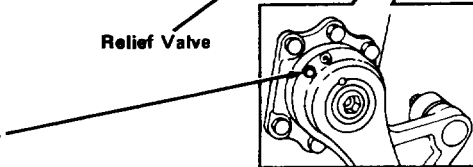

Track Adjuster

DO NOT LUBRICATE

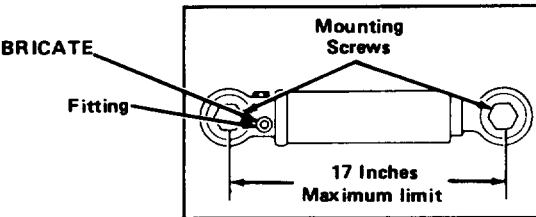

TOTAL MAN-HR

| INTERVAL | MAN-HR |
|----------|--------|
| S | 1.4 |

KEY

| LUBRICANTS/ COMPONENTS | | CAPAC- ITIES (AP- PROX) | EXPECTED TEMPERATURE# | | | INTERVALS |
|---------------------------|---|----------------------------------|----------------------------------|-----------------------------------|-------------------------------------|---|
| | | | Above +32°F (Above 0°C) | +40°F -10°F (+5°C -23°C) | 0°F to -65°F (-18°C -54°C) | |
| GAA MIL-G-10924) | GREASE, AUTOMOTIVE AND ARTILLERY Road and Idler Wheel Bearings | As req | ALL TEMPERATURES | | | S - Semi- annu- ally or Every 1500 Miles or 150 Hours |
| | Road and idler Wheel Support Arm Bearings | As req | | | | |

FOR ARCTIC OPERATION REFER TO FM 9-207

NOTES:

1. IDLER WHEEL SUPPORT ARM BEARINGS. Every 150 hours, 1500 miles, or semiannually, lubricate using grease gun with flexible adapter. Fill arms with GAA lubricant until lubricant escapes through relief valve.
2. ROAD WHEEL AND IDLER WHEEL HUB BEARINGS. Every 150 hours, 1500 miles, or semiannually, lubricate using grease gun with flexible adapter. Fill hubs with GAA lubricant until lubricant escapes through relief valve. If you see bubbles in the grease or if grease looks milky, report it to unit maintenance.
3. ROAD WHEEL SUPPORT ARM BEARINGS. Every 150 hours, 1500 miles, or semiannually, lubricate using grease gun with flexible adapter. Fill arms with GAA lubricant until lubricant escapes through relief valve. If support arm has plugs installed, remove plugs and install grease fitting and relief valve. Fill arms with GAA lubricant until lubricant escapes through relief valve. Remove grease fitting and relief valve and reinstall plugs.

LUBRICATION ORDER

LO 9-2350-266-12

19 March 1990

Supersedes LO 9-2350-266-12, dated 10 April 85.

**CARRIER, PERSONNEL, FULL TRACKED,
ARMORED FIRE SUPPORT,
M981 (NSN 2350-01-085-3792)**

References: TM 9-2350-266-10, TM 9-2350-266-20, TM 9-2350-261-20, TB 43-0210, and CL9100SL

WARNING

Dry cleaning solvent burns easily, can cause skin rash, and can give off harmful vapors. To avoid injury, keep away from open fire and use in well-ventilated area. Wear protective clothing and rubber gloves.

NOTE

When grease fitting will not accept GAA, notify unit maintenance.

4. Clean fittings with dry cleaning solvent P-D-680 prior to lubrication. Check/lubricate grease fitting points after washing or fording.

LUBRICATION ORDER

LO 9-2350-266-12

19 March 1990

Supersedes LO 9-2350-266-12, dated 10 April 85.

**CARRIER, PERSONNEL, FULL TRACKED,
ARMORED FIRE SUPPORT,
M981 (NSN 2350-01-085-3792)**

References: TM 9-2350-266-10, TM 9-2350-266-20, TM 9-2350-261-20, TB 43-0210, and CL9100SL

LUBRICANT • INTERVAL

Tow Cable
(After each use,
clean cable with
wire brush and
oil. Wipe off
excess oil.)
(See note 2) (C)

**OE/HDO S
or
OEA**

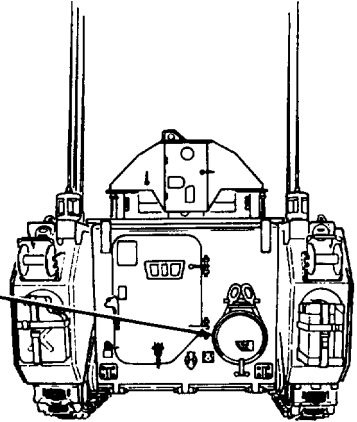

Ramp Wire Rope
(See note 1) (C)

**CW/11 S
or
GO-75W**

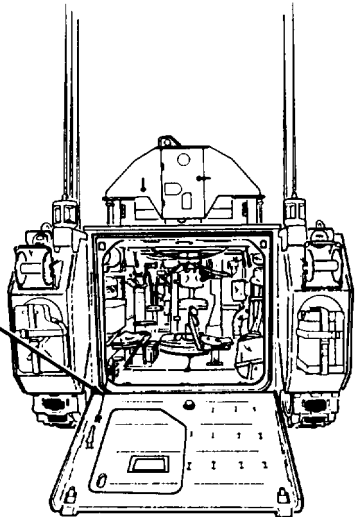

TOTAL MAN-HR

| INTERVAL | MAN-HR |
|----------|--------|
| S | 1.0 |

KEY

| LUBRICANTS/ COMPONENTS | | CAPAC- ITIES (AP- PROX) | EXPECTED TEMPERATURE # | | | INTERVALS |
|---|---|----------------------------------|-----------------------------------|---|--------------------------------------|--|
| | | | Above +32 °F (Above 0°C) | +40 °F to -10 °F (+5 °C -23 °C) | 0°F to -65 °F (-18°C -54°C) | |
| OE/HDO MIL-L-2104D) OR OEA MIL-L-46167) | LUBRICAT- ING OIL, INTERNAL COMBUSTION ENGINE Tow Cable | As req | OE/ HDO- 15/40 | OE/ HDO- 15/40 | OEA | S - Semi- annually or Every 1500 Miles |
| CW-II (VV-L-751) GO-75W (MIL-L-2105) | LUBRICAT- ING OIL CHAIN WIRE ROPE, EXPOSED GEAR Ramp Wire Rope | As req | CW-II (medium | CW-II (medium | GO- 75W | |

FOR ARCTIC OPERATION REFER TO FM 9-207

NOTES:

1. RAMP WIRE ROPE. Every 1500 miles or semiannually, lower ramp and clean exposed portion of wire rope with OE/HDO or OEA. Wipe off excess oil and coat with oil (CW-11 or GO-75W). Remove rear floor plate (TM 9-2350-266-20), raise ramp, and clean concealed portion of wire rope with OE/HDO or OEA. Wipe off excess oil and coat with CW-II or GO-75W. Report frayed or damaged wire rope to unit maintenance.

2. TOW CABLE. Every 1500 miles or semiannually and after each use, clean cable with wire rush and oil. Wipe off excess oil.

LUBRICATION ORDER

19 March 1990

LO 9-2350-266-12

Supersedes LO 9-2350-266-12, dated 10 April 85.

CARRIER, PERSONNEL, FULL TRACKED, ARMORED FIRE SUPPORT, M981 (NSN 2350-01-085-3792)

References: TM 9-2350-266-10, TM 9-2350-266-20, TM 9-2350-261-20, TB 43-0210, and C19100SL

LUBRICANT • INTERVAL

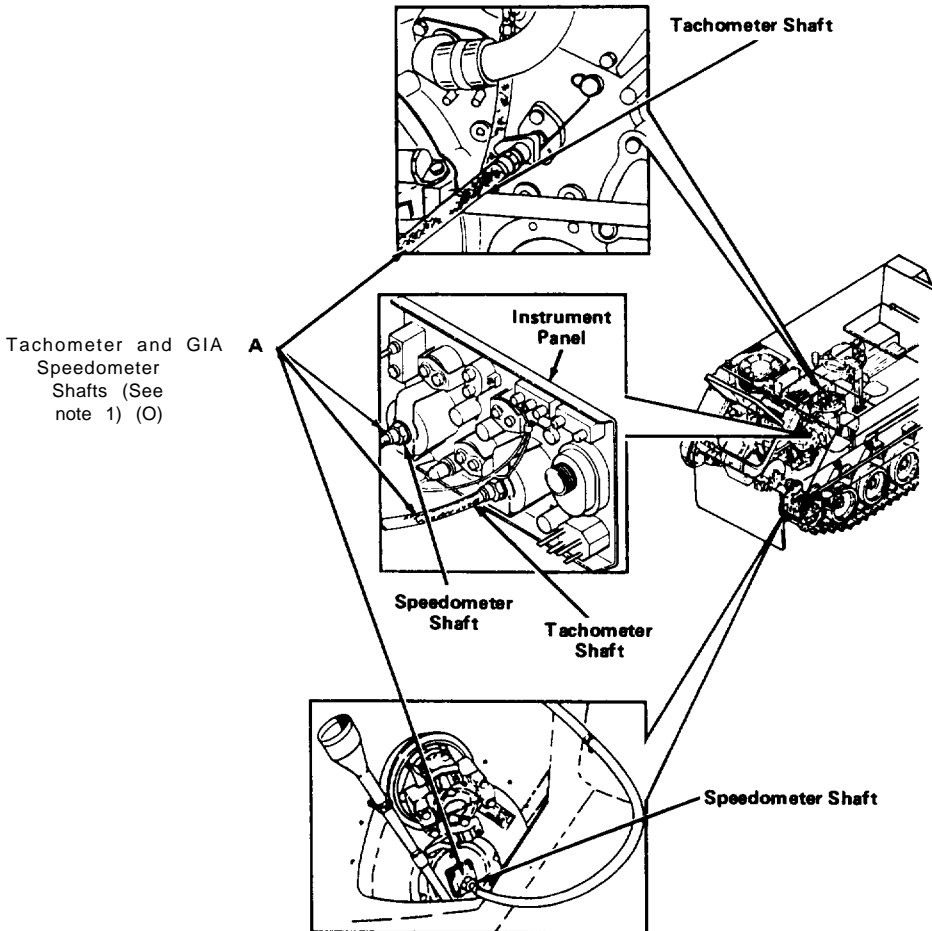

| TOTAL MAN-HR | |
|--------------|--------|
| INTERVAL | MAN-HR |
| A | 0.5 |

KEY

| LUBRICANTS/ COMPONENTS | | CAPAC- ITIES (AP- PROX) | EXPECTED TEMPERATURE | | | INTERVALS |
|---|---|----------------------------------|--------------------------------------|---|--|--|
| | | | Above + 32 ° F (Above 0° C) | + 40 ° F - 10 ° F (+ 5° C - 23 ° C) | 0° F to - 65 ° F (- 18 ° C - 54 ° C) | |
| GIA MIL-G-23827) | GREASE, INSTRUMENT, AIRCRAFT | As req | ALL TEMPERATURES | | | S - Semi- annu- ally or Every 1500 Miles A - Annu- ally |
| GAA MIL-G-10924) | GREASE, AUTOMOTIVE AND ARTILLERY | As req | | | | |
| OE/HDO MIL-L-2104D) OR OEA MIL-L-46167) | Lubricat- ING OIL, INTERNAL COMBUSTION ENGINE | es req | | | | |

FOR ARCTIC OPERATION REFER TO FM 9-207

NOTES:

1. TACHOMETER AND SPEEDOMETER SHAFTS. Annually, disconnect shafts at both ends (TM 9-2350-261-20), remove slotted washers from drive ends of cores, and remove cores from instrument panel end of shafts. Clean and lubricate cores with GIA. Insert cores in shafts. Install slotted washers and connect both ends of shafts. If tachometer adapter has a grease fitting, lubricate sparingly with lubricant GIA.
2. OIL CAN POINTS. Every 1500 miles, semiannually, or as required, lubricate ramp hinges; ramp door hinges; power plant door hinges; trim vane hinges and latches; driver's, commander's and cargo hatch hinges; control linkage pins and shafts; and seat control. Lubricate air box heater air motor. Use OE/HDO or OEA, as appropriate.
3. LUBRICATE AT TIME OF ASSEMBLY. Coat ends of suspension torsion bar, idler wheel support arm spindle and bearings, steering control linkage bearing surfaces and pins, and towing pintle shaft with GAA or GIA as specified during assembly procedure. Pack new support arm and idler hub before assembling.

LUBRICATION ORDER

LO 9-2350-266-12

19 March 1990

Supersedes LO 9-2350-266-12, dated 10 April 85.

**CARRIER, PERSONNEL, FULL TRACKED,
ARMORED FIRE SUPPORT,
M981 (NSN 2350-01-085-3792)**

References TM 9-2350-266-10, TM 9-2350-266-20, TM 9-2350-261-20, TB 43-0210, and CL9100SL

LUBRICANT & INTERVAL

Driver's Hatch
Hold Open Stop
(See note) (C)

CLP D

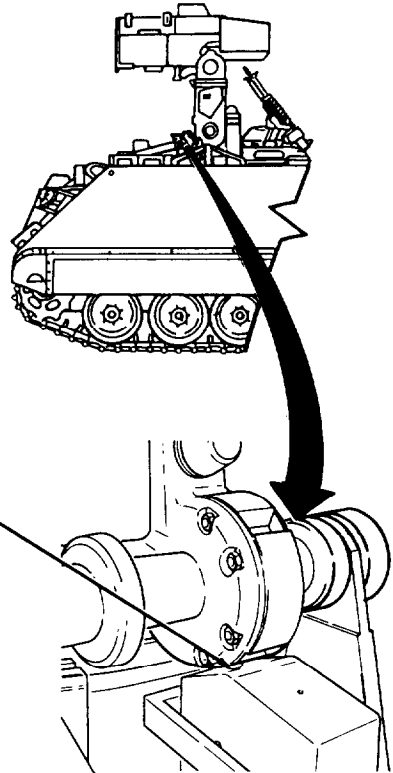

TOTAL MAN-HR

| INTERVAL | MAN-HR |
|----------|--------|
| D | 0.2 |

KEY

| LUBRICANTS/ COMPONENTS | | CAPAC- ITIES (AP- PROX) | EXPECTED TEMPERATURE# | | | INTERVALS |
|----------------------------------|---|----------------------------------|------------------------------------|--|--|-----------|
| | | | Above +32 °F (Above 0 °C) | +40°F -10°F (+5 °C) -23 °C) | 0°F to -65 °F (-18 °C -54 °C) | |
| CLP (MIL-L-63460, Grade 2) | CLEANER, LUBRICANT, PRESERVA- TIVE Driver's Hatch Hold Open Stop | As req | ALL TEMPERATURES | | | D - Daily |

FOR ARCTIC OPERATION REFER TO FM 9-207

NOTE:

DRIVER'S HATCH HOLD OPEN STOP. Before operation, during operation (as required), and weekly, inspect driver's hatch (TM 9-2350-266-10). Lightly lubricate hold open stop with CLP as required.

LUBRICATION ORDER

LO 9-2350-266-12

19 March 1990

Supersedes LO 9-2350-266-12, dated 10 April 85.

CARRIER, PERSONNEL, FULL TRACKED, ARMORED FIRE SUPPORT, M981 (NSN 2350-01-085-3792)

References: TM 9-2350-266-10, TM 9-2360.266-20, TM 9-2350-261-20, TB 43-0210, and CL9100SL

LUBRICANT • INTERVAL

Turret Hydraulic Fluid Fill (See note 2) (O) OHA FRH OHT

Turret Hydraulic Fluid Level (See note 1) (C) OHA FRH OHT

Turret Hydraulic Filter (See note 4) (O) S

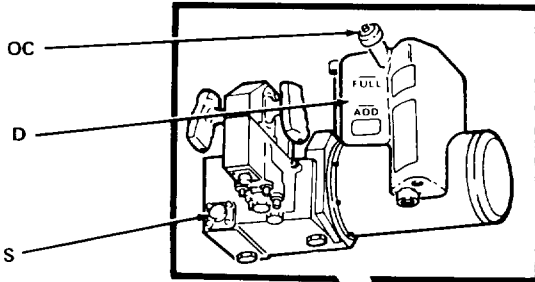

CAUTION

Cupola Ring Gear and Bearing (Do not lubricate.) (See note 3)

Turret Hydraulic System Purging (See note 5) (O)

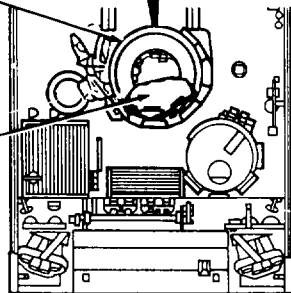

TOTAL MAN-HR

| INTERVAL | MAN-HR |
|----------|--------|
| D | 0.2 |
| S | 0.5 |

KEY

| LUBRICANTS/ COMPONENTS | | CAPAC- ITIES (AP- PROX) | EXPECTED TEMPERATURE | | | INTERVALS |
|------------------------------|--|----------------------------------|-------------------------------------|--|---|---|
| | | | Above + 32 ° F (Above 0°C) | + 40 ° F - 10 ° F (+ 5°C - 23 ° C) | 0°F to - 65 ° F (- 18 ° C - 54 ° C) | |
| OHA (MIL-H-5606) | HYDRAULIC FLUID, PETRO- LEUM BASE | 2.52 gal | ALL TEMPERATURES | | | D - Daily S - Semi- annu- ally or Every 1500 Miles, Which ever Comes First |
| FRH (MIL-H-46170) | HYDRAULIC FLUID, RUST INHIBITED, FIRE RESIS- TANT, SYN- THETIC HYDRO- CARBON BASE | | | | | |
| OHT (MIL-H-6083) | HYDRAULIC FLUID, PETROLEUM BASE, FOR PRESER- VATION AND OPERATION Turret System | | | | | |

FOR ARCTIC OPERATION REFER TO FM 9-207

NOTES:

WARNING

Hydraulic fluid is toxic to skin, eyes, and respiratory system. Wear skin, eye, and respiratory protection while doing this procedure.

1. TURRET HYDRAULIC FLUID LEVEL. Daily, check turret hydraulic fluid level at reservoir. Fluid level should be between ADD and FULL marks on reservoir.

CAUTION

DO NOT mix hydraulic fluid types. Damage to the hydraulic system may result.

2. TURRET HYDRAULIC FLUID FILL. Perform these procedures when hydraulic fluid level is below the ADD line:

a. Remove plug and cap from hydraulic reservoir.

LUBRICATION ORDER**LO 9-2350-266-12**

19 March 1990

Supersedes LO 9-2350-266-12, dated 10 April 85.

**CARRIER, PERSONNEL, FULL TRACKED,
ARMORED FIRE SUPPORT,
M981 (NSN 2350-01-085-3792)**

References: TM 9-2350-266-10, TM 9-2350-266-20, TM 9-2350-261-20, TB 43-0210, and CL9100SL

- b. Add hydraulic fluid until fluid level is at the FULL line.
 - c. Replace cap and plug.
3. CUPOLA RING GEAR AND CUPOLA BEARING. Do not lubricate cupola ring bearings or ring gear. Composition of ball bearings is affected by petroleum products, and deterioration is greatly accelerated. Dirt and debris are attracted and retained by grease with resulting abrasive action.
4. TURRET HYDRAULIC FILTER. Every 1500 miles or semiannually, drain fluid, replace filter, and replenish fluid (TM 9-2350-266-20).

WARNING

Hydraulic fluid is toxic to skin, eyes, and respiratory system. Wear skin, eye, and respiratory protection while doing this procedure.

NOTE

System may require several flushings to reach an acceptable level of 90% of specified fluid.

5. PURGING TURRET HYDRAULIC SYSTEM. Perform these procedures when changing from one hydraulic fluid type to another hydraulic fluid type:

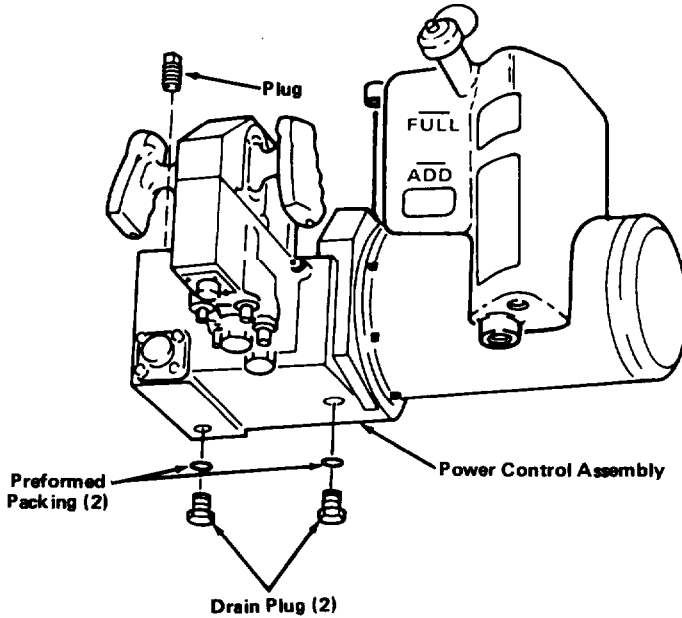

- a. Erect system, depress targeting head, bleed system pressure. Support targeting head.
- b. Remove both drain plugs. Drain fluid into suitable container.
- c. Disconnect return line to auxiliary reservoir. Install plug in reservoir and add drain line to return line. Route drain line to suitable container.
- d. Install drain plugs.

CAUTION

Keep auxiliary reservoir filled until completion of flushing.

- e. Remove blue plug and fill primary reservoir with specified fluid. Replace blue plug and fill auxiliary reservoir. Remove support.
- f. Pump hand pump five full strokes.

**CARRIER, PERSONNEL, FULL TRACKED,
ARMORED FIRE SUPPORT,****M981 (NSN 2350-01-085-3792)**

References: TM 9-2350-266-10, TM 9-2350-266-20, TM 9-2350-261-20, TB 43-0210, and CL9100SL

- g. Charge accumulator, elevate targeting head, and fill auxiliary reservoir.
- h. Charge accumulator, depress targeting head, and fill auxiliary reservoir.
- i. Charge accumulator, elevate targeting head to EL STOW, and fill auxiliary reservoir.
- j. Charge accumulator, stow system, and fill auxiliary reservoir.
- k. Charge accumulator, raise system, and fill auxiliary reservoir.
- i. Charge accumulator, track system 180° counterclockwise (ccw), return system to AZ STOW clockwise (cw).
- m. Bleed residual pressure. Support targeting head.
- n. Remove both drain plugs. Remove and discard filter. Drain fluid into suitable container.
- o. Replace drain plugs and filter. Remove plug from auxiliary reservoir and drain line from return line. Install return line to auxiliary reservoir.
- p. Remove blue plug and fill primary reservoir with specified fluid. Replace blue plug and fill auxiliary reservoir. Remove support.
- q. Exercise system ten full cycles. A cycle shall consist of:
 - (1) Erect, to stow, to erect,
 - (2) Targeting head full depression, to full elevation, to EL STOW,
 - (3) track system 180° ccw, and return to AZ STOW cw.

LUBRICATION ORDER

LO 9-2350-266-12

19 March 1990

Supersedes LO 9-2350-266-12, dated 10 April 85.

CARRIER, PERSONNEL, FULL TRACKED, ARMORED FIRE SUPPORT, M981 (NSN 2350-01-085-3792)

References: TM 9-2350-266-10, TM 9-2350-266-20, TM 9-2350-261-20, TB 43-0210, and CL9100SL

LUBRICANT • INTERVAL

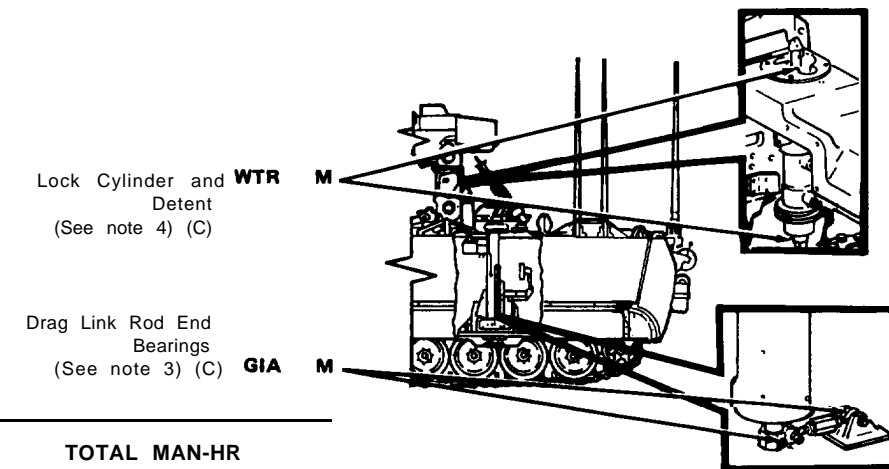
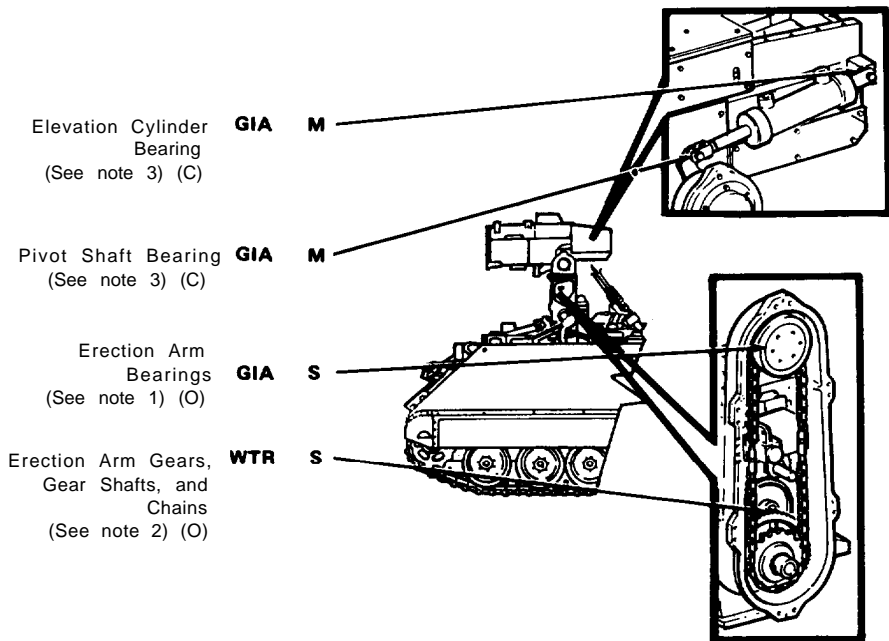

TOTAL MAN-HR

| INTERVAL | MAN-HR |
|----------|--------|
| M | 0.2 |
| S | 1.5 |

KEY

| LUBRICANTS/ COMPONENTS | | CAPACITIES (AP- PROX) | EXPECTED TEMPERATURE | | | INTERVALS |
|---------------------------|---|-----------------------------|-----------------------------------|---|--|--|
| | | | Above + 32°F (Above 0°C) | + 40°F to - 10°F (+ 5°C to - 23°C) | 0°F to - 65°F (- 18°C to - 54°C) | |
| GIA MIL-G-23827) | GREASE, INSTRUMENT, AIRCRAFT | | ALL TEMPERATURES | | | M - Monthly or Every 25 Hours or 250 Miles S - Semi-annually or Every 75 Hours or 750 Miles |
| | Pivot Shaft Bearings | As req | | | | |
| | Elevation Cylinder Bearings | As req | | | | |
| | Erection Arm Bearings | As req | | | | |
| | Drag Link Rod End Bearings | As req | | | | |
| WTR (MIL-G-81322) | GREASE, AIRCRAFT, GENERAL PURPOSE, WIDE TEMPERATURE RANGE | | | | | |
| | Erection Arm Gears, Gear Shafts, and Chains | As req | | | | |
| | Lock Cylinder and Detent | As req | | | | |

FOR ARCTIC OPERATION REFER TO FM 9-207

NOTES:

1. ERECTION ARM BEARINGS. Every 75 hours, 750 miles, or semiannually, remove erection arm covers and lubricate exposed surfaces of erection arm bearings with grease (GIA). Reinstall erection arm covers.

2. ERECTION ARM GEARS, GEAR SHAFTS, AND CHAINS. Every 75 hours, 750 miles, or semiannually, remove erection arm covers and lubricate exposed surfaces of erection arm gears, gear shafts, and chains with grease (WTR). Reinstall erection arm covers.

LUBRICATION ORDER

19 March 1990

LO 9-2350-266-12

Supersedes LO 9-2350-266-12, dated 10 April 85.

**CARRIER, PERSONNEL, FULL TRACKED,
ARMORED FIRE SUPPORT,
M981 (NSN 2350-01-085-3792)**

References: TM 9-2350-266-10, TM 9-2350-266-20, TM 9-2350-261-20, TB 43-0210, and CL9100SL

3. Every 25 turret hours, 250 miles, or monthly, lubricate at grease fitting(s).
4. Every 25 turret hours, 250 miles, or monthly, lubricate shaft ends of cylinder and detents.

Copy of this lubrication order will remain with the equipment at all times; instructions contained herein are mandatory.

BY ORDER OF THE SECRETARY OF THE ARMY:

CARL E. VUONO
General, United States Army
Chief of Staff

OFFICIAL:

WILLIAM J. MEEHAN II
Brigadier General United States Army
The Adjutant General

Distribution:

To be distributed in accordance with DA Form 12-37, Lubrication Order for Vehicle, FISTV, Carrier, Personnel, Full Tracked, Armored Fire Support, M981. **(Block Nos. 1176, 1177, 1179)**

RECOMMENDED CHANGES TO EQUIPMENT TECHNICAL PUBLICATIONS



THEN...JOT DOWN THE DOPE ABOUT IT ON THIS FORM. CAREFULLY TEAR IT OUT, FOLD IT AND DROP IT IN THE MAIL.

SOMETHING WRONG WITH PUBLICATION

FROM: (PRINT YOUR UNIT'S COMPLETE ADDRESS)

DATE SENT

PUBLICATION NUMBER

PUBLICATION DATE

PUBLICATION TITLE

BE EXACT PIN-POINT WHERE IT IS

PAGE NO.

PARA-GRAPH

FIGURE NO.

TABLE NO.

IN THIS SPACE, TELL WHAT IS WRONG AND WHAT SHOULD BE DONE ABOUT IT.

TEAR ALONG PERFORATED LINE

PRINTED NAME, GRADE OR TITLE AND TELEPHONE NUMBER

SIGN HERE

THE METRIC SYSTEM AND EQUIVALENTS

WEIGHT MEASURE

1 Centimeter = 10 Millimeters = 0.01 Meters = 0.3937 Inches
 1 Meter = 100 Centimeters = 1000 Millimeters = 39.37 Inches
 1 Kilometer = 1000 Meters = 0.621 Miles

WEIGHTS

1 Gram = 0.001 Kilograms = 1000 Milligrams = 0.035 Ounces
 1 Kilogram = 1000 Grams = 2.2 lb.
 1 Metric Ton = 1000 Kilograms = 1 Megagram = 1.1 Short Tons

LIQUID MEASURE

1 Milliliter = 0.001 Liters = 0.0338 Fluid Ounces
 1 Liter = 1000 Milliliters = 33.82 Fluid Ounces

SQUARE MEASURE

1 Sq. Centimeter = 100 Sq. Millimeters = 0.155 Sq. Inches
 1 Sq. Meter = 10,000 Sq. Centimeters = 10.76 Sq. Feet
 1 Sq. Kilometer = 1,000,000 Sq. Meters = 0.386 Sq. Miles

CUBIC MEASURE

1 Cu. Centimeter = 1000 Cu. Millimeters = 0.06 Cu. Inches
 1 Cu. Meter = 1,000,000 Cu. Centimeters = 35.31 Cu. Feet

TEMPERATURE

$5/9(^{\circ}\text{F} - 32) = ^{\circ}\text{C}$
 212° Fahrenheit is equivalent to 100° Celsius
 90° Fahrenheit is equivalent to 32.2° Celsius
 32° Fahrenheit is equivalent to 0° Celsius
 $9/5^{\circ}\text{C} + 32 = ^{\circ}\text{F}$

APPROXIMATE CONVERSION FACTORS

| TO CHANGE | TO | MULTIPLY BY |
|------------------------|----------------------|-------------|
| Inches | Centimeters | 2.540 |
| Feet | Meters | 0.305 |
| Yards | Meters | 0.914 |
| Miles | Kilometers | 1.609 |
| Square Inches | Square Centimeters | 6.451 |
| Square Feet | Square Meters | 0.093 |
| Square Yards | Square Meters | 0.836 |
| Square Miles | Square Kilometers | 2.590 |
| Acres | Square Hectometers | 0.405 |
| Cubic Feet | Cubic Meters | 0.028 |
| Cubic Yards | Cubic Meters | 0.765 |
| Fluid Ounces | Milliliters | 29.573 |
| its | Liters | 0.473 |
| arts | Liters | 0.946 |
| allons | Liters | 3.785 |
| Ounces | Grams | 28.349 |
| Pounds | Kilograms | 0.454 |
| Short Tons | Metric Tons | 0.907 |
| Pound-Feet | Newton-Meters | 1.356 |
| Pounds per Square Inch | Kilopascals | 6.895 |
| Miles per Gallon | Kilometers per Liter | 0.425 |
| Miles per Hour | Kilometers per Hour | 1.609 |

| TO CHANGE | TO | MULTIPLY BY |
|--------------------|------------------------|-------------|
| Centimeters | Inches | 0.394 |
| Meters | Feet | 3.280 |
| Meters | Yards | 1.094 |
| Kilometers | Miles | 0.621 |
| Square Centimeters | Square Inches | 0.155 |
| Square Meters | Square Feet | 10.764 |
| Square Meters | Square Yards | 1.196 |
| Square Kilometers | Square Miles | 0.386 |
| Square Hectometers | Acres | 2.471 |
| Cubic Meters | Cubic Feet | 35.315 |
| Cubic Meters | Cubic Yards | 1.308 |
| Milliliters | Fluid Ounces | 0.034 |
| Liters | Pints | 2.113 |
| Liters | Quarts | 1.057 |
| ers | Gallons | 0.264 |
| ms | Ounces | 0.035 |
| ograms | Pounds | 2.205 |
| Metric Tons | Short Tons | 1.102 |
| Newton-Meters | Pounds-Feet | 0.738 |
| Kilopascals | Pounds per Square Inch | 0.145 |
| ometers per Liter | Miles per Gallon | 2.354 |
| ometers per Hour | Miles per Hour | 0.621 |



PIN: 057583-000